

FLOOR CONSTRUCTION

General Information

Bally can provide design recommendations for many kinds of floor construction. The Bally floor panel on a properly prepared base is an excellent choice for most installations. The drawings on the following pages also show built-in insulated floors, which are recommended for certain applications.

Because requirements vary widely with individual site conditions and local construction regulations, review and approval of all such plans must be the responsibility of an engineer familiar with the circumstances of the individual installation.

Insulation Thickness for Built-in Floors

When temperature within the walk-in or refrigerated building are 30°F (-1.1°C) or above, built-in insulated floors should incorporate two layers of 1"-thick sheet urethane. When temperatures are below 30°F (1.1°C), we recommend two layers of 2"-thick sheet urethane. In either case, joints must be staggered when the urethane is installed.

Maximum Loads on Bally Floor Panels

Bally floor panels are designed to withstand uniformly distributed stationary floor loads up to 600 psf (700 psf when diamond-tread overlay is used). Whenever loads exceed these weights, a minimum of four inches of reinforced concrete must be poured on top of the floor panels. Whenever carts are used, Bally recommends the use of diamond-tread overlays or thick-set quarry tile. Also available for higher weight requirements are reinforced floors with internal I-beam support and 1/4" overlay.

Door Installation Details for Built-in Floors

(Heated stepplate shown below is available on coolers and required on freezers.)

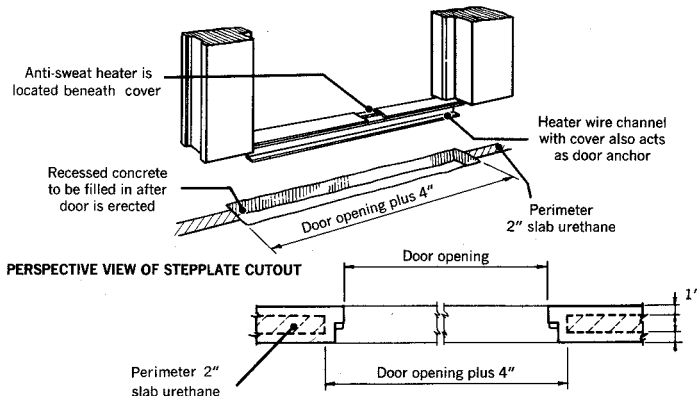
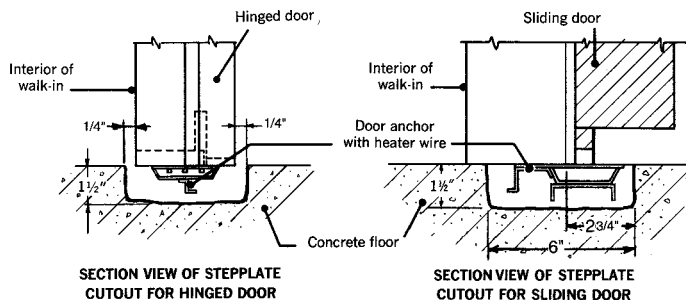

Vertical Panel Anchoring

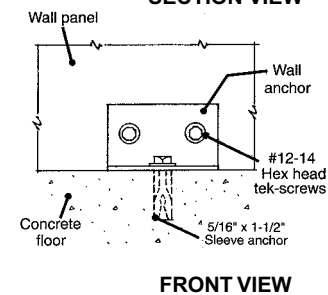
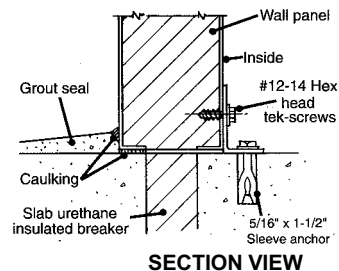

N.S.F.

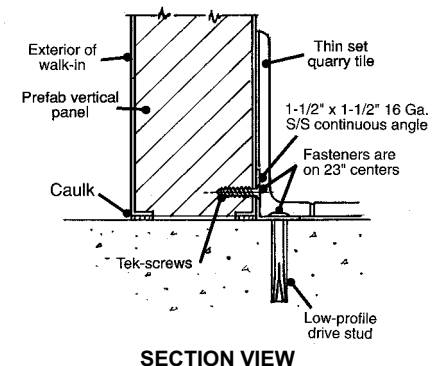
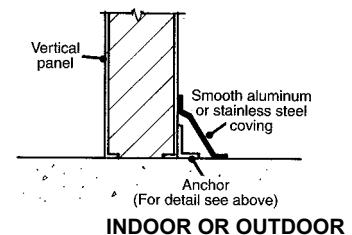
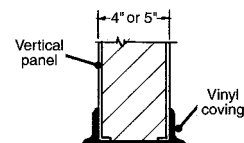

FLOOR CONSTRUCTION – CONTINUED

WALK-IN FLOORS

Because requirements vary widely with individual site conditions and local construction regulations, design, review and approval of all such plans must be the responsibility of an engineer familiar with the circumstances of the individual installation.

Additional underfloor heating and venting may be required to prevent frost heaving of the floor, depending on size, temperature of application and location. See page three, this section. (Dimension shown are for 4" – thick panels; if 5" or 6" panels are used, adapt drawings accordingly by adding 1" to inside of wall thickness.)

Bally floor panels in depressed pad (indoors only)

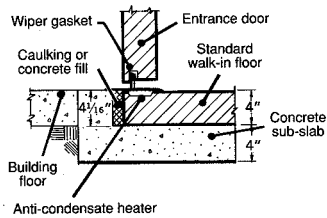

SECTION VIEW THRU DOOR

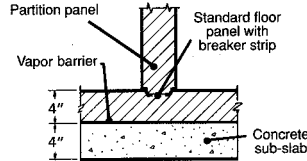

SECTION THRU PARTITION

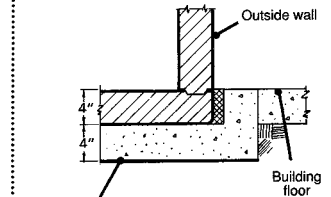

SECTION THRU OUTSIDE WALL

Bally floor panels in depressed pad with quarry tile (indoors only)

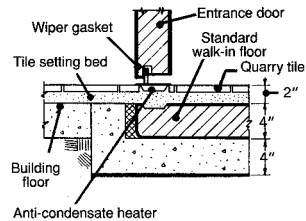

SECTION VIEW THRU DOOR

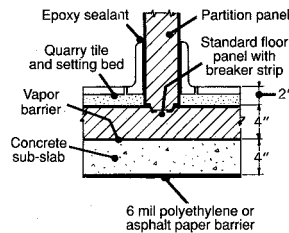

SECTION THRU PARTITION

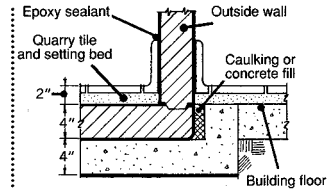

SECTION THRU OUTSIDE WALL

Non-illustrated concrete floor - coolers only (indoors, grade floor only)

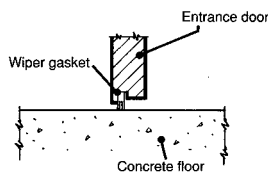

SECTION VIEW THRU DOOR

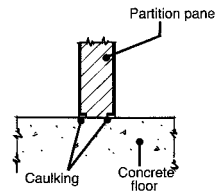

SECTION THRU PARTITION

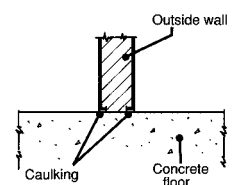

SECTION THRU OUTSIDE WALL

Thin-set quarry tile on non-insulated concrete floor - coolers only (indoors, grade floor only)

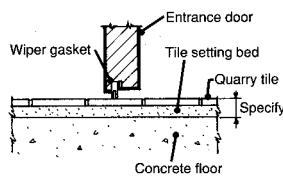

SECTION VIEW THRU DOOR

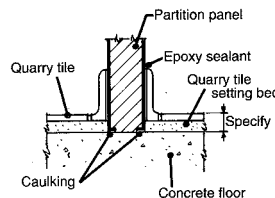

SECTION THRU PARTITION

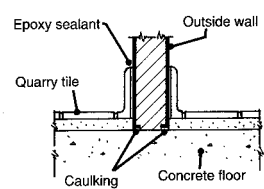

SECTION THRU OUTSIDE WALL

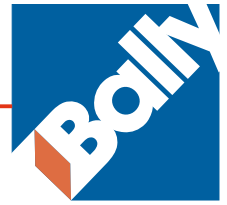

FLOOR CONSTRUCTION – CONTINUED WALK-IN FLOORS – CONTINUED

Because requirements vary widely with individual site conditions and local construction regulations, design, review and approval of all such plans must be the responsibility of an engineer familiar with the circumstances of the individual installation.

Additional underfloor heating and venting may be required to prevent frost heaving of the floor, depending on size, temperature of application and location. See page three, this section. (Dimensions shown are for 4"-thick panels; if 5" or 6" panels are used, adapt drawing accordingly by adding 1" to inside of wall thickness.)

Bally floor panels on existing floor with concrete wearing floor (indoors or outdoors)

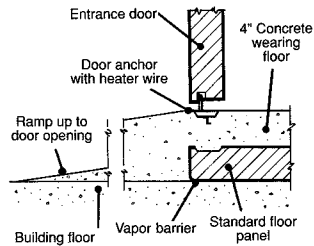

SECTION VIEW THRU DOOR

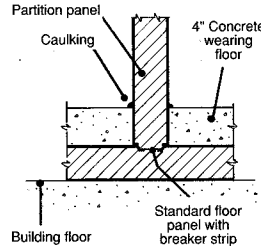

SECTION THRU PARTITION

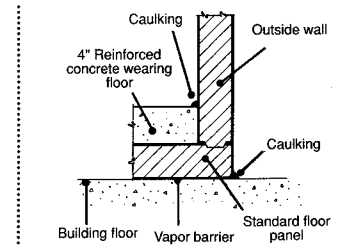

SECTION THRU OUTSIDE WALL

Bally floor panels on concrete pad (indoors or outdoors)

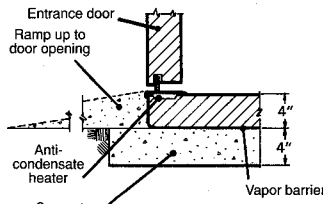

SECTION VIEW THRU DOOR

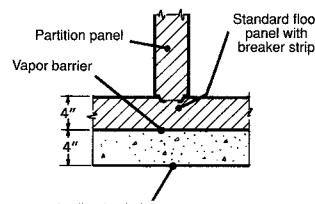

SECTION THRU PARTITION

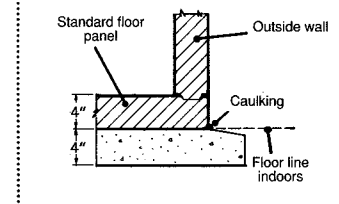

SECTION THRU OUTSIDE WALL

Built-in insulated floor (indoors or outdoors)

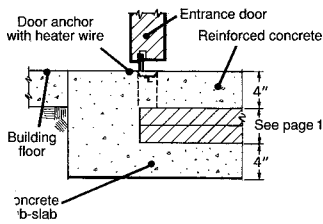

SECTION VIEW THRU DOOR

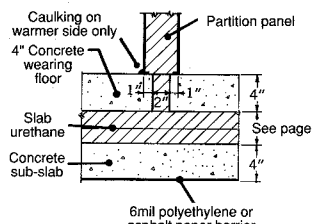

SECTION THRU PARTITION

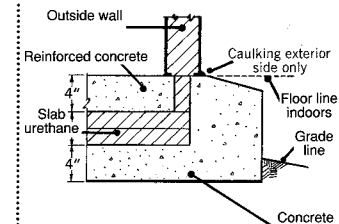

SECTION THRU OUTSIDE WALL

Built-in insulated floor (indoors)

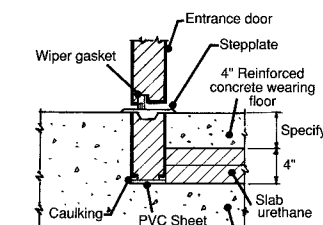

SECTION VIEW THRU DOOR

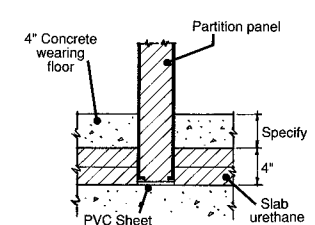

SECTION THRU PARTITION

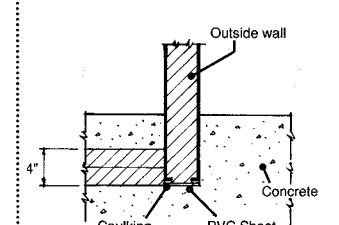

SECTION THRU OUTSIDE WALL

FLOOR CONSTRUCTION – CONTINUED

DRAIN AND VENT PIPES

Walk-ins or refrigerated building operating at or below 32°F (0°C) must be equipped with some form of underfloor heating or ventilation to prevent ground water from freezing and heaving the floor. Perforated drain and vent piping with gravel fill is Bally's preferred recommendation; alternatives include glycol piping or resistance heating.

Because requirements vary widely with individual site conditions and local construction regulations, design, review and approval of all such plans must be the responsibility of an engineer familiar with the circumstances of the individual installation

Drain and vent tiles are especially useful:

- a. When coolers or freezers are located in areas with high water tables. In such areas they drain off excess water and serve as air vents to keep the area under the slab dry.
- b. Generally when freezers or cooler-freezer combinations are more than 225 square feet in floor area and the ambient temperatures are higher than the ground temperature. These drain and vent pipes provide passages for the flow of warm air. This air flow stores heat in the ground to prevent ice build-up that could eventually cause the floor to heave.

No matter which subfloor treatment is chosen. It's vital that an engineer familiar with the circumstances of the individual installation be employed through the design and construction stages.

ASHRAE–recommended Subfloor Treatments with Drain and Vent Tiles

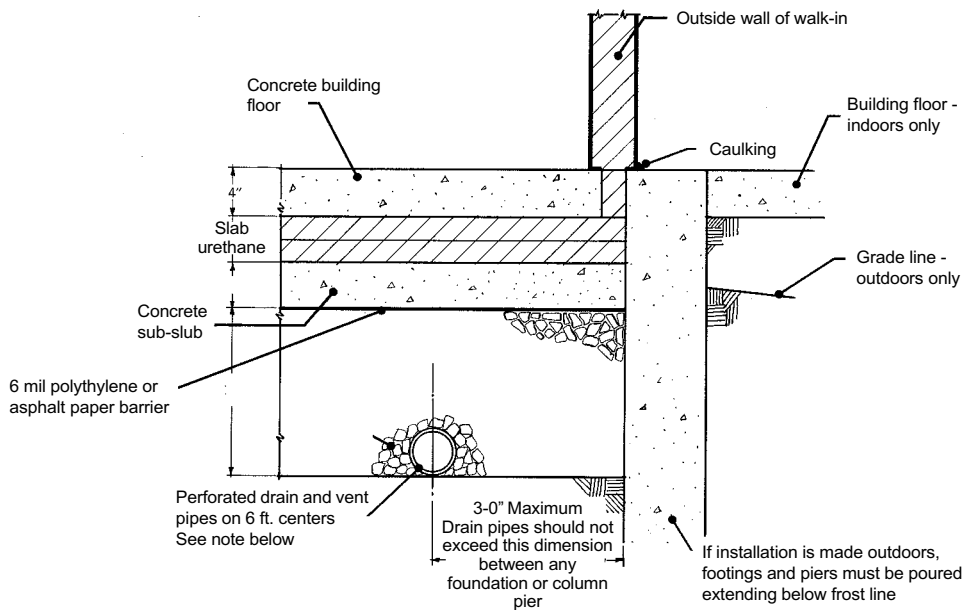

SECTION VIEW THRU OUTSIDE WALL

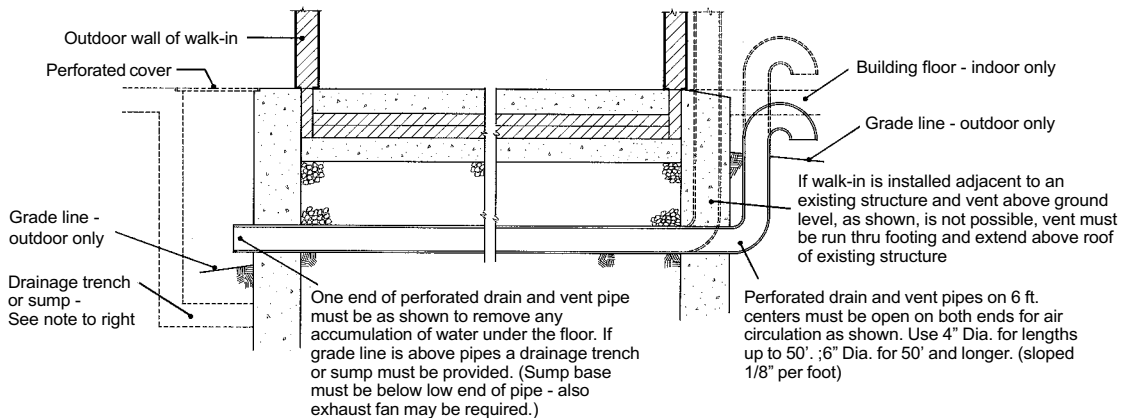

SECTION THRU LENGTH