

# Bally

## REFRIGERATORS

### VALUE LINE

REFRIGERATORS

Utilizing Environmentally Safe, CFC-free R-134a Refrigerant

#### SANDWICH UNIT REFRIGERATORS WITH CUTTING TOPS



SW27-8C

#### Models Available

- Model SW27-8C
- Model SW48-8C
- Model SW48-10C
- Model SW48-12C
- Model SW60-8C
- Model SW60-12C
- Model SW60-16C
- Model SW72-12C
- Model SW72-18C

## Refrigerator

### Standard Features

- 19" Deep, Full Length Nylon Cutting Board Mounted on 34" Deep Cutting Tops
- Unique Air Flow Distribution Allows Pan Product to Maintain 33°-41° F Being in Compliance With and Certified Under the New '98 NSF Standard For Preparation Units
- Modern, State-of-the-Art Styling
- Performance Rated Refrigeration System Utilizing Environmentally Safe R-134a Refrigerant
- Easily Serviceable Back Mounted Compressor
- 2" Non-CFC Polyurethane Foam Insulation
- Spring Loaded, Self Closing Door
- Magnetic Snap-In Gasket
- Adjustable 6" Legs
- Heavy-Duty, Epoxy-Coated Steel Shelves
- Interior Hanging Thermometer
- Cabinet Construction Consisting of Stainless Steel Front & Top, Aluminum End Panels, Case Back & Interior
- Non-Corrosive, Plasticized Fin Evaporator Coil
- Completely Enclosed, Vented & Removable Case Back
- Automatic, Energy Saving, Non-Electric Condensate Disposal
- 1/6 Size Pans, 4" Deep
- 10 ft Cord and Plug Attached

### Optional Features & Accessories

- Casters
- Remote Models-R
- Stainless Steel End Panels-SA Models
- Stainless Steel Interior & Exterior-SS Models
- Door Locks
- Electric Condensate
- Pan Opening Sizes
- Stainless Steel Legs
- Additional Shelves
- Single Over Shelf
- Double Over Shelf



c



# VALUE LINE

## REFRIGERATORS

MODEL	CU.FT.	1/6 Pans (4" Deep)	EXT.DIM. (WxDxH)	DEPTH (Cut BRD)	SHELF AREA	SHELVES	DOORS	HP	VOLTS	AMPS	FANS	SHIP WGHT (lbs)
SW27-8C	7.4	8	27 <sup>1</sup> / <sub>2</sub> x35x43	19	3.5	1	1	1/5	115	6.0	2	180
SW48-8C	13.4	8	48x35x43	19	6.8	2	2	1/5	115	6.9	3	270
SW48-10C	13.4	10	48x35x43	19	6.8	2	2	1/5	115	6.9	3	270
SW48-12C	13.4	12	48x35x43	19	6.8	2	2	1/5	115	6.9	3	315
SW60-8C	17.0	8	60x35x43	19	8.1	2	2	1/4	115	7.8	3	315
SW60-12C	17.0	12	60x35x43	19	8.1	2	2	1/4	115	7.8	3	315
SW60-16C	17.0	16	60x35x43	19	8.1	2	2	1/4	115	7.8	3	315
SW72-12C	20.6	12	72x35x43	19	10.2	3	3	1/4	115	8.7	4	398
SW72-18C	20.6	18	72x35x43	19	10.2	3	3	1/4	115	8.7	4	398

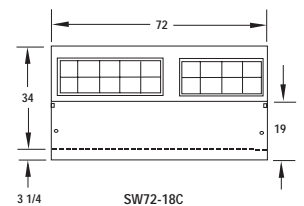
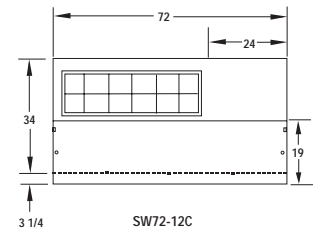
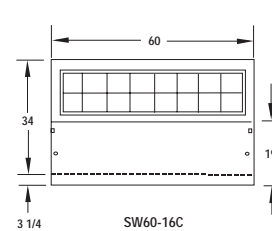
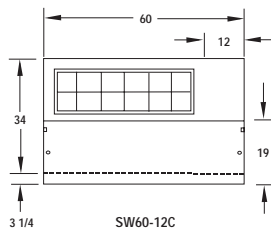
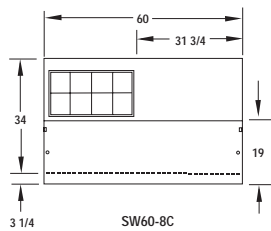
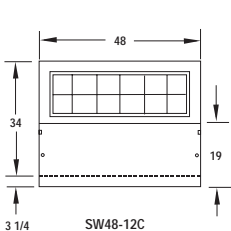
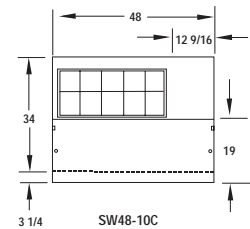
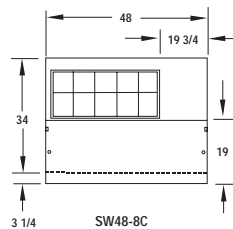
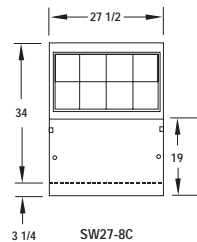
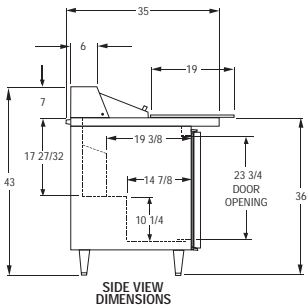
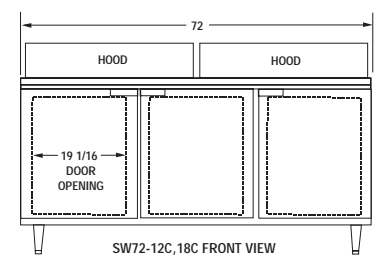
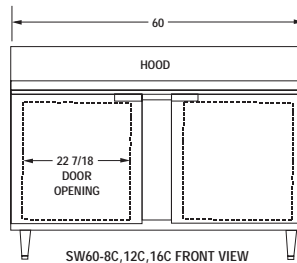
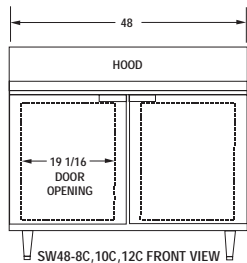
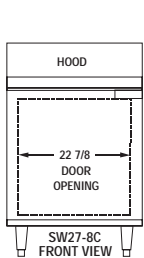

A Division of BALMAC International, Inc.

61 Broadway Suite 1900, New York, NY 10006-2701 • (212) 898-9699 Fax: (212) 514-9234 - [www.bmil.com](http://www.bmil.com)

VLSW27-5/00