

# Bally

## REFRIGERATORS

### VALUE LINE FREEZERS

### Refrigerator

#### SLIM LINE FREEZERS

Utilizing Environmentally Safe, CFC-free R-404A Refrigerant



#### Standard Features

- Modern, State-of-the-Art Styling
- Performance Rated Refrigeration System Designed for 0°F Cabinet
- High Density Non-CFC Polyurethane Foamed-In-Place Insulation
- Will Accommodate 12 x 20 Pans
- Chrome Plated Flow Line Handles
- Cam-Action Lift-Off Hinges
- Self-Closing Doors
- Automatic Interior Lighting
- Magnetic Snap-In Door Gasket
- Field Rehingable Doors (model 1FSE only)
- Automatic Electric Condensate Evaporator
- 5" Casters
- Heavy-Duty, Epoxy-Coated Steel Shelves
- External Dial Thermometer
- Automatic Electric Defrost

Standard (S/S Front, Aluminum End Panels & Interior)

Suffix SA (S/S Exterior, Aluminum Interior)

Suffix SS (S/S Exterior & Interior)

#### Optional Features & Accessories

- |                                 |                                   |
|---------------------------------|-----------------------------------|
| • Legs                          | • Stainless Steel Shelves         |
| • Stainless Steel Case Back     | • Digital Thermometer             |
| • Rehinging of Doors            | • Increased Refrigeration Systems |
| • Remote                        | (only for 2 sec Model)            |
| • Half Door                     | • Shallow Depth                   |
| • Pass-Thru (2 Sec. Model Only) | (2 Sec. Model Only)               |





CHARACTERISTICS	1FSE	2FSE
	One Section Reach-In	Two Section Reach-In
<b>DIMENSIONAL DATA</b>		
Net Capacity (cu. ft.)	15	30
Width, Overall (in.)	17 <sup>3</sup> / <sub>4</sub>	36 <sup>1</sup> / <sub>4</sub>
Depth, Overall (Incl. Hlds.) (in.)	35 <sup>1</sup> / <sub>2</sub>	35 <sup>1</sup> / <sub>2</sub>
Depth (Less Door(s)) (in.)	32	32
Depth (Door(s) Open 90°) (in.)	47 <sup>3</sup> / <sub>8</sub>	48 <sup>1</sup> / <sub>2</sub>
Clear Door Width (in.)	13 <sup>3</sup> / <sub>4</sub>	13
Clear Full-Door Height (in.)	61 <sup>1</sup> / <sub>4</sub>	58 <sup>5</sup> / <sub>8</sub>
Clear Half-Door Height (in.)	30 <sup>7</sup> / <sub>8</sub>	N/A
Height, Overall (Incl. 5" Casters) (in.)	82 <sup>1</sup> / <sub>4</sub>	82 <sup>1</sup> / <sub>4</sub>
No. of Full Door(s)	1	2
No. of Half Door(s)	2	N/A
No. of Shelves	4	3
Shelf Area (sq. ft.)	9.3	24.4
<b>REFRIGERATION DATA</b>		
Condensing Unit Size (H.P.)	<sup>1</sup> / <sub>3</sub>	<sup>1</sup> / <sub>2</sub>
Capacity (BTU/Hr)*	1590	1840
<b>ELECTRICAL DATA</b>		
Cabinet Specifications	115/60/1	115/60/1
Feed Wires (Incl. Ground)	3	3
Condensing Unit Specs.	115/60/1	115/60/1
Total Amperes	7.5	10.3
Cabinet Amperes	1.6	1.8
Defrost Amperes	4.0	6.5
Power Supply Cord	yes	yes
<b>SHIPPING DATA</b>		
Height – crated (in.)	85 <sup>1</sup> / <sub>2</sub>	85 <sup>1</sup> / <sub>2</sub>
Width – crated (in.)	31 <sup>5</sup> / <sub>8</sub>	42
Depth – crated (in.)	42	42
Volume – crated (cu. ft.)	65	87
Weight Std – crated (lbs.)	290	445
Weight SS – crated (lbs.)	350	505
Weight Std – uncrated (lbs.)	190	345
Weight SS – uncrated (lbs.)	250	405

\*Rating @ -15°F Evaporator, 90° Ambient

Note: If the cabinet is located directly against wall and/or under low ceiling, a minimum clearance of 2" is required.

Note: All specifications subject to change without notice.

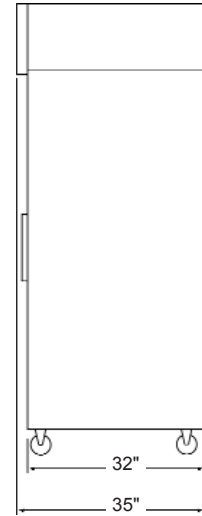

SIDE VIEW

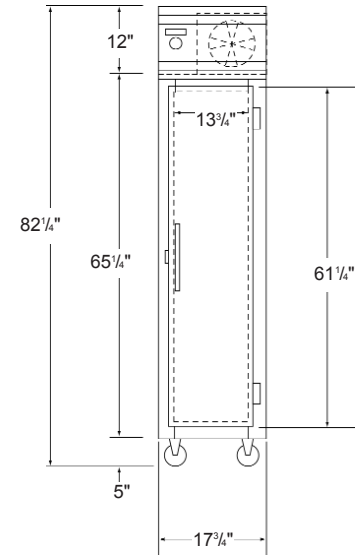

1FSE  
FRONT VIEW

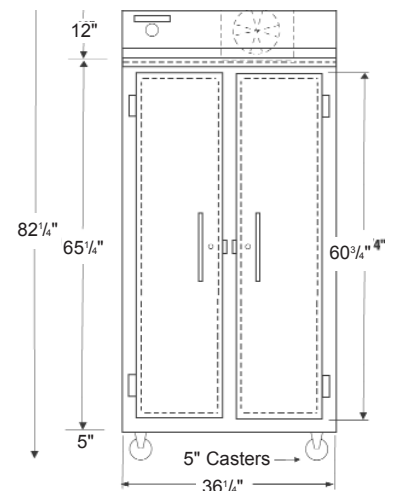

2FSE  
FRONT VIEW



A Division of BALMAC International, Inc.  
 61 Broadway Suite 1900, New York, NY 10006-2701  
 (212) 898-9699 Fax: (212) 514-9234  
[www.bmil.com](http://www.bmil.com) - [bmil@bmil.com](mailto:bmil@bmil.com)