

Bally

REFRIGERATORS

Designer line

REFRIGERATORS

Utilizing Environmentally Safe, CFC-free R-134a Refrigerant



Models Available

- Roll-Thru
- Glass Door
- Remote
- Consult Factory

ROLL-IN & ROLL-THRU REFRIGERATORS

Standard Features

- Modern, State-Of-The-Art Styling
- Performance Rated, "Plug" Refrigeration System Utilizing Environmentally Safe R-134a Refrigerant
- 3" High Density, Non-CFC Polyurethane Foam Insulation
- Chrome-Plated Flow Line Handles
- Cam-Action Lift-Off Hinges
- Self-Closing Doors
- Cylinder Lock in Each Door
- Automatic Hot Gas Condensate Evaporator
- 27³/₈" Wide, 66¹/₂" High Door Opening
- External Digital Thermometer
- Removable Stainless Steel Rack Guides
- Magnetic Snap-In Door Gaskets
- Unique Air Flow Distribution Ducts Keep Pan Product at Uniformly Constant Temperatures
- Removable Stainless Steel Ramps

Standard (S/S Front, Aluminum Ends & Interior)
 Suffix SA (S/S Exterior, Aluminum Interior)
 Suffix SS (S/S Exterior & Interior)

REFRIGERATION SYSTEM

A "performance rated", air-cooled hermetically sealed, capillary type refrigeration system is installed on the top of each refrigerator. Plasticized fin coil and air circulating fans are contained within a concealed "plug" type insulated housing, readily accessible on the top of the cabinet and separate from the food zone to increase food storage capacity. The entire "plug" system is fully charged with environmentally safe R-134a refrigerant and mounted on a sturdy steel, rail type base, which can be easily removed if freezer conversion is desired. Refrigerators are designed to maintain 38 to 40 degrees Fahrenheit (3-5 degrees Centigrade) while operating with an unrestricted air supply in a maximum ambient temperature of 100 degrees Fahrenheit. All condensate water is evaporated by an automatic, non-electric, corrosion-resistant condensate evaporator. A strict quality-assurance team inspects all materials and components to the most exacting standards. All models are factory performance-tested for a minimum of 16 hours prior to crating.

CABINET CONSTRUCTION

All materials are of top quality, and are assembled under rigid supervision conforming to strict quality assurance requirements. The cabinet front, doors, and interior bottoms are constructed of heavy gauge polished stainless steel for durability. All cabinet joints and seams are sealed vapor tight. Case is of all metal welded construction and is internally supported and braced for rigid unit construction. Cabinet design eliminates overlapping panels with raw edges. Cabinet body and doors are insulated with non-CFC, foamed in place polyurethane foam with an average thickness of 3 inches to ensure increased energy efficiency. Full-length louvered air grille located above the doors allows equal air circulation to the condensing unit. Easily removable, low-wattage, anti-sweat door heaters concealed by a non-metallic, non-conductive, high-impact thermal breaker strip eliminate condensate build up on the cabinet front. Automatic interior lighting is controlled by door openings. Cabinets are equipped with an easily removable stainless steel ramp and interior rack guides.

DOOR CONSTRUCTION

Doors shells are constructed of a heavy gauge stainless steel and are internally braced and urethane foam insulated for rigidity. Door corners are of welded construction and polished. Replaceable snap-in door gaskets are self-adjusting, heavy-duty, magnetic type. Doors handles and hinges are chrome-plated and non-corrosive. Doors are provided with built-in cylinder locks, which are keyed alike. Hinges are cam action, lift-off type featuring a positive safety stop at 120 degree



SPECIFICATIONS	DL1RI-SS ONE SECTION		DL2RI-SS TWO SECTION		DL3RI-SS THREE SECTION	
	ROLL-IN	ROLL-THRU	ROLL-IN	ROLL-THRU	ROLL-IN	ROLL-THRU
DIMENSIONAL DATA						
Net Capacity (cu. ft.)	32	32	64	64	96	96
Width, Overall (in.)	35 ¹ / ₄	35 ¹ / ₄	68 ¹ / ₂	68 ¹ / ₂	101 ³ / ₄	101 ³ / ₄
Depth, Overall, Incl. Hlds. (in.)	35 ¹ / ₂	39	35 ¹ / ₂	39	35 ¹ / ₂	39
Depth (Less Door(s))(in.)	32	32	32	32	32	32
Depth (Door(s) Open 90°)(in.)	65	98	65	98	65	98
Clear Door Width (in.)	27 ³ / ₈	27 ³ / ₈	27 ³ / ₈	27 ³ / ₈	27 ³ / ₈	27 ³ / ₈
Clear Full-Door Height (in.)	66 ¹ / ₂	66 ¹ / ₂	66 ¹ / ₂	66 ¹ / ₂	66 ¹ / ₂	66 ¹ / ₂
Height, Overall (in.)	86	86	86	86	86	86
No. of Full Door(s)	1	2	2	4	3	6
Rack Capacity*	1	1	2	2	3	3
REFRIGERATION DATA						
Condensing Unit Size (H.P.)	¹ / ₃	¹ / ₃	¹ / ₂	¹ / ₂	³ / ₄	³ / ₄
Capacity (BTU/Hr)**	2560	2560	4010	4010	5930	5930
Refrigerant	R-134a	R-134a	R-134a	R-134a	R-134a	R-134a
ELECTRICAL DATA						
Cabinet Specifications	115/60/1	115/60/1	115/60/1	115/60/1	115/208-230/60/1	115/208-230/60/1
Feed Wires (Incl. Ground)	3	3	3	3	4	4
Condensing Unit Specs.	115/60/1	115/60/1	115/60/1	115/60/1	208-230/60/1	208-230/60/1
Total Amperes	9.1	9.6	14.7	15.7	11.3	12.8
Cabinet Amperes	1.9	2.4	3.1	4.1	4.3	5.8
Defrost Amperes	-	-	-	-	-	-
Power Supply Cord	yes	yes	yes	yes	no	no
SHIPPING DATA						
Height-crated (in.)	90	90	90	90	90	90
Width-crated (in.)	43	43	77	77	109	109
Depth-crated (in.)	42	42	42	42	42	42
Volume-crated (cu. ft.)	94	94	168	168	238	238
Weight Std-crated (lbs.)	415	475	680	780	840	960
Weight SS-crated (lbs.)	505	580	720	825	925	1050
Weight Std - uncrated (lbs.)	330	380	540	625	670	760
Weight SS - uncrated (lbs.)	405	460	575	660	740	840

*Maximum Rack Size including wheels - 27"W x 29"D x 66¹/₄"H

**Rating @ +25° Evaporator, 90° Ambient

Note: All Specifications subject to change without notice

Note: If the cabinet is located directly against a wall and/or under low ceiling, a minimum clearance of 2" is required.

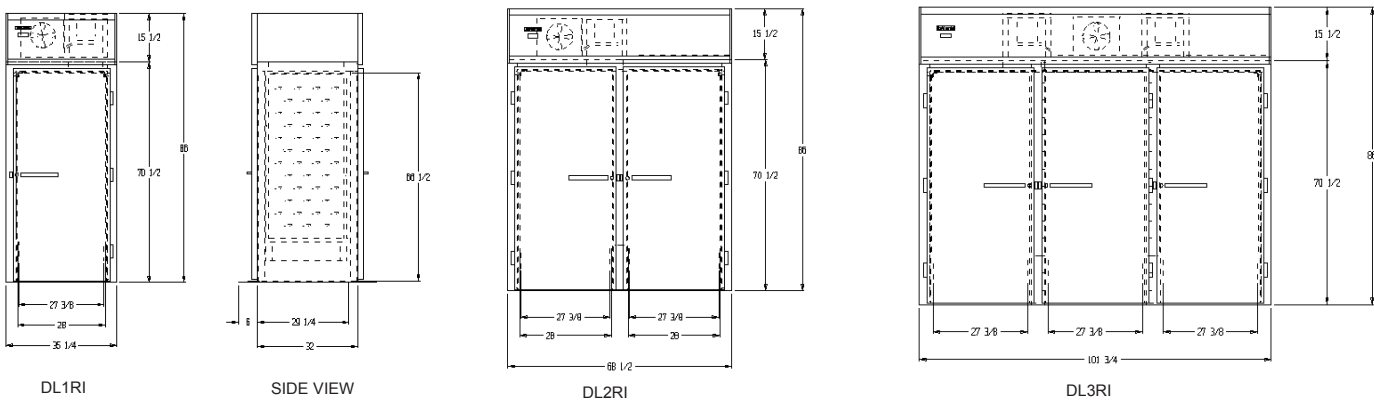

A Division of BALMAC International, Inc.
 61 Broadway, Suite 1900, New York, NY 10006-2701
 (212) 898-9699 Fax: (211) 514-9234
www.bmil.com - bmil@bmil.com