

# Bally

## REFRIGERATORS

### *Designer line*

#### REFRIGERATORS

Utilizing Environmentally Safe, CFC-free R-404A Refrigerant



MC5-SCW

#### Models Available

- MC3-SCW      •MC3-DCW
- MC4-SCW      •MC4-DCW
- MC5-SCW      •MC5-DCW

### COLD WALL MILK COOLERS

#### Standard Features

- Modern, State-Of-The-Art Styling
- Available in both Single (S) and Double (D) Service Access
- Cold Wall, Performance Rated, R-404A Refrigeration
- System Designed to Keep Milk Cold Prior to Serving
- Cabinet Construction Consisting Of Stainless Steel Top, Lid and Door, White Finish Steel Body and Galvanized Steel Interior with Reinforced Stainless Steel Floor
- Non-Corrosive, Heavy Duty, Epoxy Coated Steel Wire Floor Racks
- Heavy Duty, Stainless Steel Lid and Door Hinges and Latches
- 2" High Density, Non-CFC Polyurethane Foamed-In-Place Insulation
- Easily Serviceable Rear Mounted Compressor
- Exterior Mounted, Easily Readable Dial Thermometer
- Snap-In Lid And Door Gasket
- Door Cylinder Security Lock
- Swivel Type, Heavy-Duty Casters (Front Locking)
- Easily Accessible, Convenient Cleanout Floor Drain
- Extra Long, 10' Power Supply Cord And Plug Attached

#### Optional Features & Accessories

- Stainless Steel Exterior      •Stainless Steel Interior
- Wrap Around Bumpers      •Corner Bumpers
- 6" Adjustable Legs

#### REFRIGERATION SYSTEM

The self-contained refrigeration system is concealed within an easily serviceable rear mounted, slide out chassis. A bottom mounted full-length rear grill allows for even air circulation to condensing unit. The "performance rated", hermetically sealed, capillary type cold wall refrigeration system is designed to keep milk cold prior to serving. A strict quality assurance team inspects all materials and components to certify that each model conforms to the most exacting standards. All models are performance tested for a minimum of 16 hours prior to crating

#### CABINET CONSTRUCTION

All materials are of top quality, and are assembled under rigid supervision conforming to strict quality assurance requirements. Case is of all metal welded construction and is internally supported and braced for rigid unit construction. All cabinet joints and seams are vapor-tight sealed.

#### INSULATION

All cabinet walls, top, bottom, lids and doors have an average of 2" of high density, non-CFC, polyurethane foamed in place insulation

#### DOOR & LID CONSTRUCTION

Doors and lids are constructed of a heavy gauge stainless steel and are internally braced and urethane foam insulated for rigidity. Doors, lid hinges, and latches are heavy duty and constructed of stainless steel. All gaskets are self-adjusting and snap-in type, creating a positive seal. Doors are provided with built in cylinder security locks.



**SPECIFICATIONS**

**MC3-SCW    MC3-DCW    MC4-SCW    MC4-DCW    MC5-SCW    MC5-DCW**

**DIMENSIONAL DATA**

Net Capacity (cu.ft.)	13	13	20	20	24	24
Crate Capacity (13" x13" x11")	8	8	12	12	16	16
Crate Capacity (19" x13" x11")	4	4	8	8	10	10
Width, Overall (in.)	34	34	49	49	58	58
Depth (in.)	33	33	33	33	33	33
Height, Overall (in.)	41½	41½	41½	41½	41½	41½
Service Access	Single	Double	Single	Double	Single	Double
Condensing Unit Size (HP)	¼	¼	⅓	⅓	⅓	⅓
Refrigerant	R-404A	R-404A	R-404A	R-404A	R-404A	R-404A
Cabinet Electrical	115/60/1	115/60/1	115/60/1	115/60/1	115/60/1	115/60/1
Power Cord Supply	yes	yes	yes	yes	yes	yes

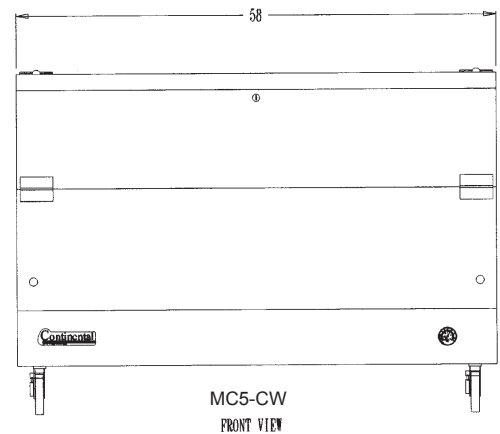
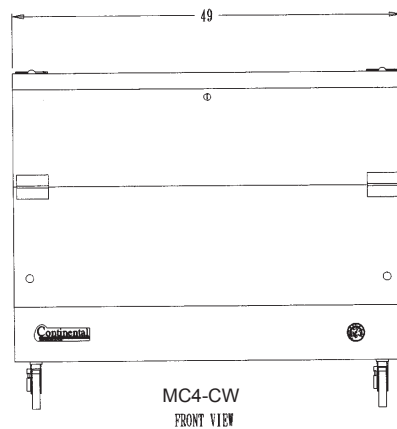
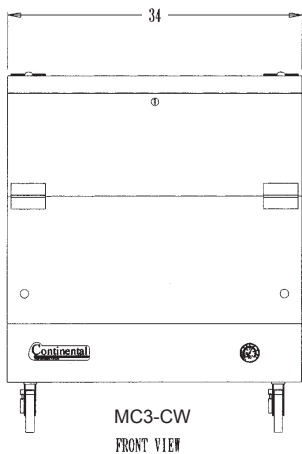
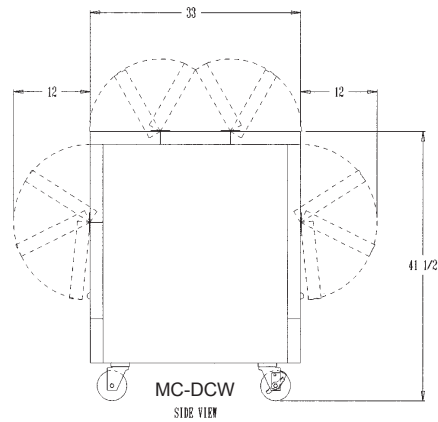
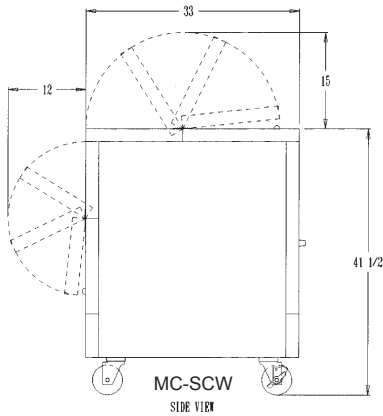

A Division of BALMAC International, Inc.  
61 Broadway, Suite 1900, New York, NY 10006-2701  
(212) 898-9699 Fax: (212) 514-9234  
[www.bmil.com](http://www.bmil.com) - [bmil@bmil.com](mailto:bmil@bmil.com)