

Bally

REFRIGERATORS

Designer-line
PROOFERS

ROLL-IN PROOFERS
EXTENDED HEIGHT
(72" CART CAPACITY)

Standard Features

- Modern, State-of-the-Art Styling
- Designed for 90% RH Maximum and 105°F
- Precise, Accurate Control of Temperature and Humidity
- 27³/₈" Wide, 73" High Door Openings
- 3" Non-CFC Polyurethane Foam Insulation
- Cam-Action Lift-Off Hinges
- Automatic Door Closers
- Automatic Interior Lighting
- Cylinder Lock In Each Door
- Removable Stainless Steel Ramps
- Magnetic Snap-In Door Gasket
- Exterior Digital Thermometer
- Removable Stainless Steel Rack Guides



Standard (S/S Front, Aluminum Ends & Interior)
Suffix SA (S/S Exterior, Aluminum Interior)
Suffix SS (S/S Exterior & Interior)

Cabinet Construction

All materials are of top quality, assembled to conform with strict quality-assurance requirements. The cabinet front and doors are constructed of heavy-gauge polished stainless steel for durability. All cabinet joints and seams are sealed vapor-tight. Case is of all metal, welded construction and internally supported and braced for a rigid unit construction. Cabinet design eliminates overlapping panels with raw edges. Cabinet body and doors are insulated with non-CFC, foamed-in-place polyurethane foam to ensure increased energy efficiency. Automatic interior lighting is controlled by door openings. Cabinets are equipped with an easily removable, stainless steel ramp and interior rack guides.

Door Construction

Door shells are constructed of heavy-gauge stainless steel and are internally braced and urethane-foam-insulated for rigidity. Door corners are of welded construction and polished. Door gaskets are self-adjusting, heavy-duty, magnetic type. Door handles and hinges are chrome-plated and non-corrosive. Doors are provided with built-in cylinder locks which are keyed alike. Hinges are cam action, lift-off type featuring positive safety stop at 120 degrees.



c





PROOFERS

SPECIFICATIONS
DIMENSIONAL DATA

| | DL1WI-SS-EP ONE SECTION | DL2WI-SS-EP TWO SECTION | DL3WI-SS-EP THREE SECTION |
|-----------------------------------|--|--|--|
| | ROLL-IN | ROLL-IN | ROLL-IN |
| Net Capacity (cu. ft.) | 34 | 68 | 101 |
| Width, Overall (in.) | 35½ | 66⅞ | 101¼ |
| Depth, Overall, Incl. Hdls. (in.) | 34½ | 34½ | 34½ |
| Depth (Less Door(s))(in.) | 32⅜ | 32⅜ | 32⅜ |
| Depth (Door(s) Open 90°)(in.) | 65 | 65 | 65 |
| Clear Door Width (in.) | 27⅜ | 27⅜ | 27⅜ |
| Clear Full-Door Height (in.) | 73 | 73 | 73 |
| Height, Overall (in.) | 88 | 88 | 88 |
| No. of Full Door(s) | 1 | 2 | 3 |
| Rack Capacity* | 1 | 2 | 3 |

ELECTRICAL DATA

| | 115/208-230/60/1 | 115/208-230/60/1 | 115/208-230/60/1 |
|-------------------------------|------------------|------------------|------------------|
| Cabinet Specifications | 115/208-230/60/1 | 115/208-230/60/1 | 115/208-230/60/1 |
| Feed Wires (Incl. Ground) | 4 | 4 | 4 |
| Total Amperes | 7.8 | 14.5 | 22.4 |
| Total Wattage @ 208-230 Volts | 1500 | 3000 | 4500 |
| Power Supply Cord | no | no | no |
| Water Connection | ⅜" | ⅜" | ⅜" |
| Drain Line | ⅜" | ⅜" | ⅜" |

SHIPPING DATA

| | 90 | 90 | 90 |
|------------------------------|-----|-----|-----|
| Height-crated (in.) | 90 | 90 | 90 |
| Width-crated (in.) | 43 | 77 | 109 |
| Depth-crated (in.) | 42 | 42 | 42 |
| Volume-crated (cu. ft.) | 94 | 168 | 238 |
| Weight Std-crated (lbs.) | 415 | 680 | 840 |
| Weight SS-crated (lbs.) | 505 | 720 | 925 |
| Weight Std - uncrated (lbs.) | 330 | 540 | 670 |
| Weight SS - uncrated (lbs.) | 405 | 575 | 740 |

*Maximum Rack Size including wheels - 27"W x 29"D x 72"H

Note: All Specifications subject to change without notice

Note: If the cabinet is located directly against a wall and/or under low ceiling, a minimum clearance of 2" is required.

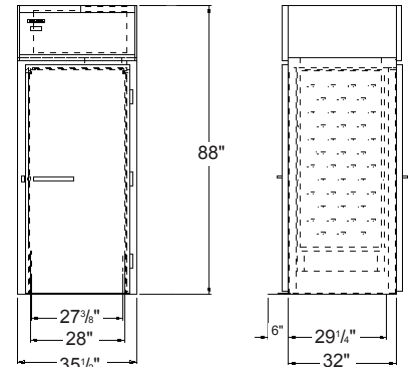

DL1WI-EP
FRONT VIEW

SIDE VIEW

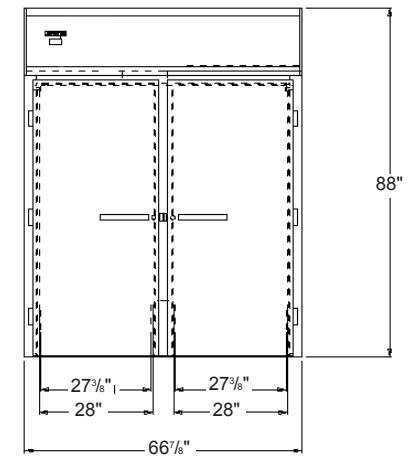

DL2WI-EP
FRONT VIEW

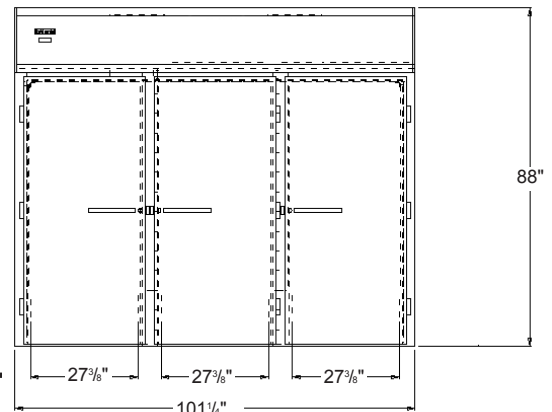

DL3WI-EP
FRONT VIEW



A Division of BALMAC International, Inc.
61 Broadway, Suite 1900, New York, NY 10006-2701
(212) 898-9699 Fax: (212) 514-9234
www.bmil.com - bmil@bmil.com