

Bally

REFRIGERATORS

Designer-line
DUAL TEMPS

Utilizing Environmentally Safe, CFC-free R-134a & R-404A Refrigerant



DL2RF-SS



DL3RRF-SS

Standard (S/S Front, Aluminum Ends & Interior)
Suffix SA (S/S Exterior, Aluminum Interior)
Suffix SS (S/S Exterior & Interior)

SIDE BY SIDE DUAL TEMPS

Standard Features

- Modern, State-of-the-Art Styling
- Performance Rate "Plug" Refrigeration Systems
- 3" Non-CFC Polyurethane Foam Insulation
- Chrome-Plated Flow Line Handles
- Cam-Action Lift-Off Hinges
- Self-Closing Doors
- Magnetic Snap-In Gaskets
- Cylinder Lock In Each Door
- Automatic Hot Gas Condensate Evaporator
- Adjustable 6" Stainless Steel Legs
- External Digital Thermometers
- Automatic Electric Defrost on Freezer System
- Automatic Interior Lighting

Optional Features & Accessories

- Half-Door
- Remote Shelves
- Stainless Steel Shelves
- Consult Factory
- Pass-Thru
- Casters
- Pan Slides
- Correctional Facility Package

REFRIGERATION SYSTEM

Two "performance rated", air cooled hermetically sealed, capillary type refrigeration systems are installed on top of each dual temp. Plasticized fin coil and air circulating fans are contained within each concealed "plug" type insulated housing, readily accessible on the top of the cabinet and separate from each food zone to increase food storage capacity. Both "plug" systems are fully charged with refrigerant and mounted on a sturdy steel, rail-type base which can be easily removed. Refrigerator sections are designed to maintain 38 to 40 degrees Fahrenheit (3 to 5 degrees Centigrade), and Freezer sections 0 degrees Fahrenheit (-18 degrees Centigrade) while operating with an unrestricted air supply in a maximum ambient temperature of 100 degrees Fahrenheit. Freezer "Plug" systems have an automatic electric defrost timer which initiates defrost cycles at predetermined intervals. All condensate water is evaporated by an automatic, non-electric, corrosion-resistant condensate evaporator. A strict quality-assurance team inspects all materials and components to certify that each model conforms to the most exacting standards. All models are factory performance tested for a minimum of 16 hours prior to crating.

CABINET CONSTRUCTION

All materials are of top quality, assembled to conform with strict quality-assurance requirements. The cabinet front and doors are constructed of heavy-gauge polished stainless steel for durability. All cabinet joints and seams are sealed vapor tight. Case is of all metal, welded construction and internally supported and braced for a rigid unit construction. Cabinet design eliminates overlapping panels with raw edges. Cabinet body, doors and plug are insulated with non-CFC, foamed-in-place polyurethane foam with an average thickness of 3 inches to ensure increased energy efficiency. Full-length louvered air grille located above the doors allows equal air circulation to the condensing unit. Easily removable, low-wattage, anti-sweat door heaters concealed by a non-metallic, non-conductive, high-impact thermal breaker strip eliminate condensate build-up on the cabinet front. Automatic interior lighting is controlled by door openings. Cabinets are equipped with 6-inch adjustable stainless steel legs.

SHELVING

Shelves are designed for heavy-duty use with .306" diameter frame and brace members and .140" diameter fill wires spaced 3/4" apart. Shelves are welded steel and epoxy-coated for a durable, long, rust-free service life. Adjustments are in 1/2 increments and a wide door opening allows the use of a variety of optional pan and tray slide types.

DOOR CONSTRUCTION

Door shells are constructed of heavy gauge stainless steel and are internally braced and urethane-foamed-insulated for rigidity. Door corners are of welded construction and polished. REplaceable snap-in gaskets are self-adjusting, heavy-duty, magnetic type. Door handles and hinges are chrome-plated and non-corrosive. Doors are provided with built-in cylinder locks which are keyed alike. Hinges are cam action, lift-off type featuring positive safety stop at 120 degrees.





DUAL TEMPS

CHARACTERISTICS	DL2RF-SS	DL3RRF-SS	DL3RFF-SS
DIMENSIONAL DATA			
Net Capacity (cu. ft.)	21/21	50/21	21/50
Width, Overall (in.)	52	78	78
Depth, Overall (Incl. Hlds.) (in.)	35 1/2	35 1/2	35 1/2
Depth (Less Door(s)) (in.)	32	32	32
Depth (Doors(s) Open 90°) (in.)	55 1/2	55 1/2	55 1/2
Clear Door Width (in.)	19 3/8	19 3/8	19 3/8
Clear Full-Door Height (in.)	58 5/8	58 5/8	58 5/8
Clear Half-Door Height (in.)	27 1/2	27 1/2	27 1/2
Height, Overall (Inc. 6" Legs)(in.)	83 1/4	83 1/4	83 1/4
No. of Full Door(s)	2	3	3
No. of Half Door(s)	4	6	6
No. of Shelves	6	9	9
Shelf Area (sq. ft.)	20.4/20.4	40.8/20.4	20.4/40.8
Tray Slide Capacity (Half)	12 ea.	12 ea.	12 ea.
Tray Slide Capacity (Full)	25 ea.	25 ea.	25 ea.

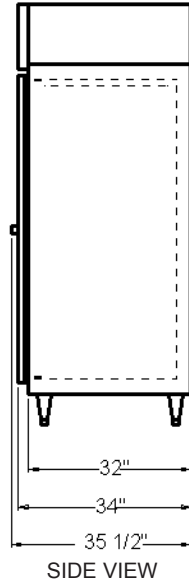

REFRIGERATION DATA

Condensing Unit Size (H.P.)	1/4, 1/3	1/3, 1/3	1/4, 1/2
Capacity (BTU/hr)**	1940/1590	2560/1590	1940,2470

ELECTRICAL DATA

Cabinet Specifications	115/60/1	115/60/1	115/60/1
Feed Wires (Incl. Ground)	3/3	3/3	3/3
Condensing Unit Specs.	115/60/1	115/60/1	115/60/1
Total Amperes	6.9/7.6	9.1/7.6	6.9/9.8
Defrost Amperes	4.3	4.3	9.6
Power Supply Cord	yes	yes	yes

SHIPPING DATA

Height – crated (in.)	82	82	82
Width – crated (in.)	55	81	81
Depth – crated (in.)	37	37	37
Volume – crated (cu.ft.)	97	142	142
Weight Std – crated (lbs.)	630	835	835
Weight SS – crated (lbs.)	710	950	950
Weight Std – uncrated (lbs.)	460	625	625
Weight SS – uncrated (lbs.)	380	740	740

*Rating @ +25°F Evaporator, 90° Ambient (Refrigerator)

*Rating @ -15°F Evaporator, 90° Ambient (Freezer)

Note: All Specifications subject to change without notice.

Note: If the cabinet is located directly against wall and/or under low ceiling, a minimum clearance of 2" required.

Cabinet upper side panels and refrigeration plug systems can be easily removed and reinstalled at installation site where space limitations are confining.

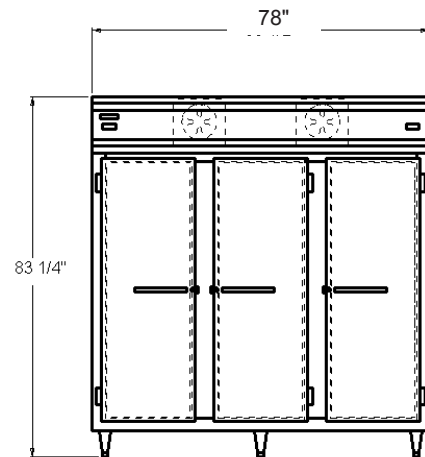
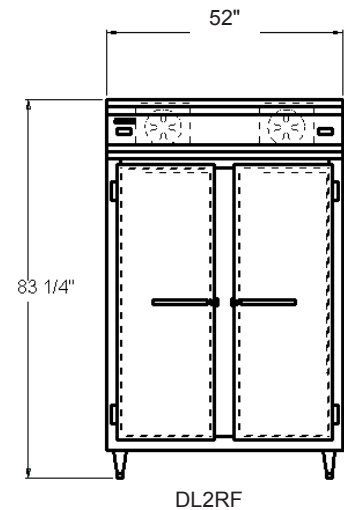

A Division of BALMAC International, Inc.
 61 Broadway, Suite 1900, New York, NY 10006-2701
 (212) 898-9699 Fax: (212) 514-9234
www.bmil.com - bmil@bmil.com