

Bally

REFRIGERATORS

Designer line

FREEZERS

Utilizing Environmentally Safe, CFC-free R-404A Refrigerant

EXTRA-WIDE FREEZERS

Standard Features

- Modern, State-of-the-Art Styling
- Performance Rated "Plug" Refrigeration System
- 3" Non-CFC Polyurethane Foam Insulation
- Chrome-Plated Flow Line Handles
- Cam-Action Lift-Off Hinges
- Self-Closing Doors
- Magnetic Snap-In Door Gasket
- Cylinder Lock In Each Door
- Automatic Hot Gas Condensate Evaporator
- Adjustable 6" Stainless Steel Legs
- Heavy-Duty, Epoxy-Coated Steel Shelves
- External Digital Thermometer
- Automatic Electric Defrost

Optional Features & Accessories

- Half Door
- Remote
- Hinged Glass Display Door
- Pass-Thru
- Consult Factory



DL1FX-SS

DL1FE-SS

DL3FE-SS

DL2FE-SS

Standard (S/S Front, Aluminum Ends & Interior)
 Suffix -SA (S/S Exterior & Aluminum Interior)
 Suffix -SS (S/S Exterior & Interior)

Refrigeration System

A "performance rated" air cooled hermetically sealed, capillary type refrigeration system is installed on the top of each freezer. Plasticized fin coil and air circulating fans are contained within a concealed "plug" type insulated housing, readily accessible on the top of the cabinet and separate from the food zone to increase food storage capacity. The entire "plug" system is fully charged with refrigerant and mounted on a sturdy steel, rail-type base which can be easily removed if refrigerator conversion is desired. Freezers are designed to maintain 0 degrees Fahrenheit (-18° Centigrade) while operating with an unrestricted air supply in a maximum ambient temperature of 100° Fahrenheit. Automatic electric defrost timer initiates defrost cycles at predetermined intervals. All condensate water is evaporated by an automatic, non-electric, corrosion-resistant condensate evaporator. A strict quality-assurance team inspects all materials and components to certify that each model conforms to the most exacting standards. All models are factory performance tested for a minimum of 16 hours prior to crating.

Cabinet Construction

All materials are of top quality, assembled to conform with strict quality-assurance requirements. The cabinet front and doors are constructed of heavy-gauge polished stainless steel for durability. All cabinet joints and seams are sealed vapor tight. Case is of all metal, welded construction and internally supported and braced for a rigid unit construction. Cabinet design eliminates overlapping panels with raw edges. Cabinet body and doors are insulated with non-CFC, foamed-in-place polyurethane foam with an average thickness of 3 inches to ensure increased energy efficiency. Full-length louvered air grille located above the doors allows equal air circulation to the condensing unit. Easily removable, low-wattage, anti-sweat door heaters concealed by a non-metallic, non-conductive, high-impact thermal breaker strip eliminate condensate build up on the cabinet front. Automatic interior lighting is controlled by door openings. Cabinets are equipped with 6-inch adjustable stainless steel legs.

Shelving

Shelves are designed for heavy-duty use with .306" diameter frame and brace members and .140" diameter fill wires spaced 3/4" apart. Shelves are welded steel and epoxy-coated for a durable, long, rust-free service life. Adjustments are in 1/2" increments and a wide door opening allows the use of a variety of optional pan and tray slide types.

Door Construction

Door shells are constructed of heavy-gauge stainless steel and are internally braced and urethane-foam-insulated for rigidity. Door corners are of welded construction and polished. Replaceable snap-in door gaskets are self-adjusting, heavy-duty, magnetic type. Door handles and hinges are chrome-plated and non-corrosive. Doors are provided with built-in cylinder locks which are keyed alike. Hinges are cam action, lift-off type featuring positive safety stop at 120 degrees.



c



Designer line

FREEZERS

CHARACTERISTICS	DL1FE-SS One Section		DL1FX-SS One Section-Extra Wide		DL2FE-SS Two Section		DL3FE-SS Three Section	
	Reach-In	Pass-Thru	Reach-In	Pass-Thru	Reach-In	Pass-Thru	Reach-In	Pass-Thru
DIMENSIONAL DATA								
Net Capacity (cu.ft.)	22	22	32	32	52	52	75	75
Width, Overall (in.)	28 1/2	28 1/2	36 1/4	36 1/4	57	57	85 1/2	85 1/2
Depth, Overall (Incl. Hlds.) (in.)	35 1/2	39	35 1/2	39	35 1/2	39	35 1/2	39
Depth (Less Door(s)) (in.)	32	32	32	32	32	32	32	32
Depth (Door(s) Open 90°) (in.)	58	84	66	100	58	84	58	84
Clear Door Width (in.)	21 7/8	21 7/8	29 5/8	29 5/8	21 7/8	21 7/8	21 7/8	21 7/8
Clear Full-Door Height (in.)	58 5/8	58 5/8	58 5/8	58 5/8	58 5/8	58 5/8	58 5/8	58 5/8
Clear Half-Door Height (in.)	27 1/2	27 1/2	27 1/2	27 1/2	27 1/2	27 1/2	27 1/2	27 1/2
Height, Overall (Incl. 6" Legs) (in.)	83 1/4	83 1/4	86 3/4	86 3/4	86 3/4	87 1/4	87 1/4	87 1/4
No. of Full Door(s)	1	2	1	2	2	4	3	6
No. of Half Door(s)	2	4	2	4	4	8	6	12
No. of Shelves	3	3	3	3	6	6	9	9
Shelf Area (sq. ft.)	20.4	20.4	24.4	24.4	40.8	40.8	61.2	61.2
Tray Slide Capacity (Half)	11 ea.	11 ea.	11 ea.	11 ea.	11 ea.	11 ea.	11 ea.	11 ea.
Tray Slide Capacity (Full)	24 ea.	24 ea.	24 ea.	24 ea.	24 ea.	24 ea.	24 ea.	24 ea.
REFRIGERATION DATA								
Condensing Unit Size (H.P.)	1/3	1/3	1/2	1/2	1/2	3/4	3/4	1
Capacity (BTU/Hr)*	1590	1590	1840	1840	2470	3575	3575	4325
ELECTRICAL DATA								
Cabinet Specifications	115/60/1	115/60/1	115/60/1	115/60/1	115/60/1	115/208-230/60/1	115/208-230/60/1	115/208-230/60/1
Feed Wires (Incl. Ground)	3	3	3	3	3	4	4	4
Condensing Unit Specs.	115/60/1	115/60/1	115/60/1	115/60/1	115/60/1	208-230/60/1	208-230/60/1	208-230/60/1
Total Amperes	7.6	8.0	12.5	12.8	12.8	9.3	9.3	12.1
Cabinet Amperes	1.6	1.9	1.8	2.1	1.9	2.9	2.9	3.9
Defrost Amperes	4.3	4.3	9.6	9.6	9.6	9.6	9.6	9.6
Power Supply Cord	yes	yes	yes	yes	yes	no	no	no
SHIPPING DATA								
Height – crated (in.)	85 1/2	85 1/2	85 1/2	85 1/2	85 1/2	85 1/2	85 1/2	85 1/2
Width – crated (in.)	31 5/8	31 5/8	42	42	64	64	90	90
Depth – crated (in.)	42	42	42	42	42	42	42	42
Volume – crated (cu. ft.)	63	63	87	87	129	129	181	181
Weight Std – crated (lbs.)	355	385	455	460	610	720	865	960
Weight SS – crated (lbs.)	415	445	515	520	690	800	985	1075
Weight Std – uncrated (lbs.)	255	285	355	360	440	550	655	750
Weight SS – uncrated (lbs.)	315	345	415	420	520	630	770	865

*Rating @ -15°F Evaporator, 90° Ambient

Note: All specifications subject to change without notice.

Note: If the cabinet is located directly against wall and/or under low ceiling, a minimum clearance of 2" is required.

Cabinet upper side panels and refrigeration plug system can be easily removed and reinstalled at installation site where space limitations are confining.

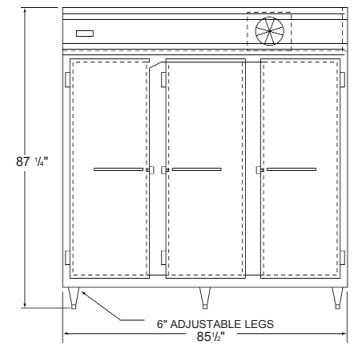
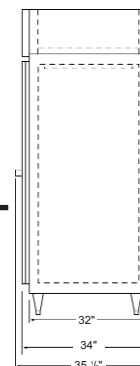
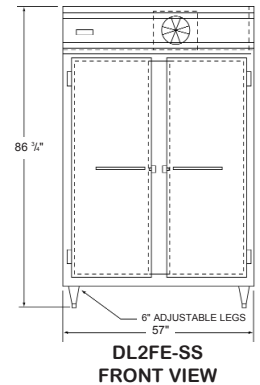
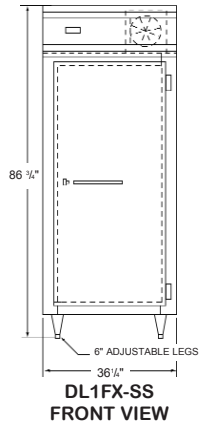
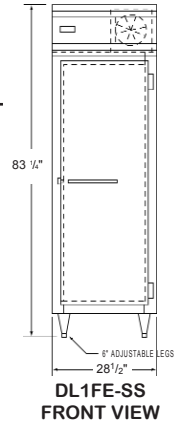

A Division of Balmac International, Inc.
61 Broadway, Suite 1900, New York, NY 10006-2701
Tel: (212) 898-9699 Fax: (212) 514-9234
www.bmil.com - bmil@bmil.com